



Area Representation:



# CASE SEALERS

*Competitive Pricing Without Sacrificing Quality*

<p><b>SD-553</b></p>	<p><b>TB-552</b></p>	<p><b>TS-554</b></p>
<p>Semi-Automatic Case Sealer</p>  <p>Only \$3,500</p>	<p>Semi-Automatic Case Sealer</p> 	<p>Semi-Automatic Case Sealer</p> 
<p><b>SR-555</b></p>	<p><b>SD-557</b></p>	<p><b>SR-559</b></p>
<p>Semi-Automatic Random Case Sealer</p> 	<p>Fully Automatic Case Sealer</p> 	<p>Fully Automatic Random Case Sealer</p> 
<p><b>PIRANHA OR BARRACUDA TAPE HEADS</b></p>		<p><b>CE-563</b></p>
<p>Piranha</p> 	<p>Barracuda</p>  <p><b>Taking a bite out of the competition.</b> Available in Standard Paint or Stainless Steel.</p>	<p>Semi-Automatic Case Erector/ Pack Station</p> 

## SEMI-AUTOMATIC CASE SEALER

### SD-553 – UNIFORM SIZES – SIDE BELT DRIVES

For applications where previously erected cases are loaded and flaps are manually closed.

- Plug-in Operation
- Dual Masts with twin lead screws for stability
- Precise Top and Bottom sealing
- Side Mounted Compression Rollers for tight seals
- Heavy Duty Side-Belt Drives ensure square cases
- Adjustable Leg Supports
- Easy case-size change-over – two crank handles
- Piranha Tape Heads for accurate and consistent sealing

#### SD-553

Speed: Up to 2,400 Cases/Hour (75 fpm)  
Case Length: 6" minimum – no maximum  
Case Width: 4" minimum – 21" maximum  
Case Height: 4" minimum – 21" maximum

Electrical: 110VAC-1PH-60Hz – 10 Amps  
Air: None  
Dimensions: 52" L x 40" W x 55-70" H  
Weight: 300 lbs

Only  
\$3,500

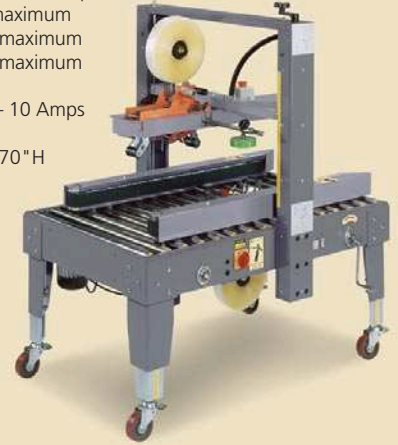

## SEMI-AUTOMATIC CASE SEALER

### TB-552 – UNIFORM SIZES – TOP and BOTTOM DRIVES

Extremely versatile for standard sized cases. Four belts positively control cases. Manual flap folding.

- Plug-in Operation
- Dual Masts with twin lead screws for stability
- Precise Top and Bottom sealing
- Dual, Top Mounted Belt Drives for top control
- Heavy Duty Side-Belt Drives ensure square cases
- Side Mounted Compression Rollers for tight seals
- Adjustable Leg Supports
- Easy case-size change-over – two crank handles
- Piranha Tape Heads for accurate and consistent sealing

#### TB-552

Speed: Up to 2,400 Cases/Hour (75 fpm)  
Case Length: 6" minimum – no maximum  
Case Width: 7" minimum – 21" maximum  
Case Height: 4" minimum – 20" maximum

Electrical: 110VAC-1PH-60Hz – 10 Amps  
Air: None  
Dimensions: 40" L x 31" W x 50-65" H  
Weight: 300 lbs

Note: If the case height exceeds its length, it may not be suitable for this machine.

**Capacity for larger cases. Please call or e-mail case sizes.**



## FULLY AUTOMATIC CASE SEALER

### SD-557 – UNIFORM SIZES

For applications where previously erected cases are loaded with product and automated case closing and sealing is required. Features include:

- Plug-in Operation – No operator assistance needed
- Dual Masts with twin lead screws for stability
- Precise Top and Bottom sealing
- Front, Back and Side Flaps Automatically Folded
- Side Mounted Compression Rollers for tight seals
- Heavy Duty Side-Belt Drives ensure square cases
- Adjustable Leg Supports
- Easy case-size change-over – two crank handles
- Piranha Tape Heads for accurate and consistent sealing
- Side Safety Mesh Steel Guarding

#### SD-557

Speed: Up to 700 Cases/Hour  
(75 fpm belt speed)  
Case Length: 6" minimum – 30" maximum  
Case Width: 4.75" minimum – 21" maximum  
Case Height: 4" minimum – 20" maximum

Electrical: 110VAC--60Hz – 10 Amps  
Air: 1 SCFM @ 70 psi  
Dimensions: 79" L x 40" W x 61-72" H  
Weight: 650 lbs

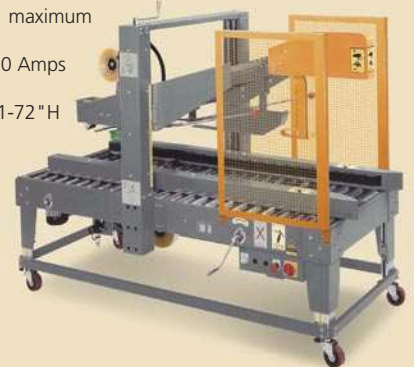

## SEMI-AUTOMATIC CASE SEALER

### TS-554 – UNIFORM SIZES – TOP and SIDE BELT DRIVES

For applications requiring top control of difficult cases such as tall and/or narrow sizes. Manual flap folding.

- Plug-in Operation
- Dual Masts with twin lead screws for stability
- Precise Top and Bottom sealing
- Dual, Top Mounted Belt Drives for top control
- Heavy Duty Side-Belt Drives ensure square cases
- Side Mounted Compression Rollers for tight seals
- Adjustable Leg Supports
- Easy case-size change-over – two crank handles
- Piranha Tape Heads for accurate and consistent sealing

#### TS-554

Speed: Up to 2,400 Cases/Hour (75 fpm)  
Case Length: 6" minimum – no maximum  
Case Width: 4" minimum – 21" maximum  
Case Height: 4" minimum – 21" maximum

Electrical: 110VAC-1PH-60Hz – 10 Amps  
Air: None  
Dimensions: 52" L x 39" W x 55-70" H  
Weight: 375 lbs



## SEMI-AUTOMATIC RANDOM CASE SEALER

### SR-555 – RANDOM SIZES – SIDE BELT DRIVES

Extremely versatile for applications that utilize multiple case sizes. Manual flap folding.

- Plug-in Operation
- Precise Top and Bottom sealing
- Automatic Case Height Adjustment w/ cushion
- Self Adjusting Side-Belt Drives for case-width
- Side Mounted Compression Rollers for tight seals
- Optional Swing-out Mesh Steel Guarding
- Adjustable Leg Supports
- Piranha Tape Heads for accurate and consistent sealing

#### SR-555

Speed: Up to 400 Cases/Hour (75 fpm)  
Case Length: 6" minimum – no maximum  
Case Width: 4.75" minimum – 21" maximum  
Case Height: 6" minimum – 20" maximum

Electrical: 110VAC-1PH-60Hz - 10 Amps  
Air: 1 SCFM @ 70 psi  
Dimensions: 52" L x 37" W x 50-61" H  
Weight: 450 lbs



Note: If the case height exceeds its length, it may not be suitable for this machine.

**Capacity for larger cases. Please call or e-mail case sizes.**

## FULLY AUTOMATIC RANDOM CASE SEALER

### SR-559 – RANDOM SIZES

For applications where multiple sized cases require closing and sealing with a single machine.

- Plug-in Operation – No operator assistance needed
- Automatic Case Height Adjustment w/ cushion
- Self Adjusting Side-Belt Drives for case-width
- Precise Top and Bottom sealing
- Front, Back and Side Flaps Automatically Folded
- Side Mounted Compression Rollers for tight seals
- Adjustable Leg Supports
- Roller top deck with photo-eye case sensors
- Piranha Tape Heads for accurate and consistent sealing
- Side Safety Mesh Steel Guarding

#### SR-559

Speed: Up to 300 Cases/Hour (75 fpm belt speed)  
Case Length: 6" minimum – 30" maximum  
Case Width: 4" minimum – 27" maximum  
Case Height: 6" minimum – 20" maximum

Electrical: 220VAC-3PH-60Hz – 20 Amps  
Air: SCFM @ 70 psi  
Dimensions: 79" L x 45" W x 66-76" H  
Weight: 750 lbs



Note: If the case height exceeds its length, it may not be suitable for this machine.

**Capacity for larger cases. Please call or e-mail case sizes.**

## SEMI-AUTOMATIC CASE ERECTOR/PACK STATION

### CE-563

When connected to any Case Sealer, it enables one person to form, pack and seal corrugated cases in a single operation.

- Plug-in Operation
- Folds major flaps and holds case steady while packing
- Both Automatic and Manual Modes
- Adjustable Leg Supports
- Improve safety by eliminating costly repetitive strain injury problems
- Improve productivity and eliminate extra labor
- Moves case after packing
- Foot pedal or hand operated advancement

### CE-563

Case Length: 6" minimum – 27" maximum  
Case Width: 7" minimum – 15.5" maximum  
Case Height: 4" minimum – No maximum

Air: 1 SCFM @ 70 psi  
Dimensions: 57" L x 32" W x 30-39" H  
Weight: 370 lbs



## OPTIONS

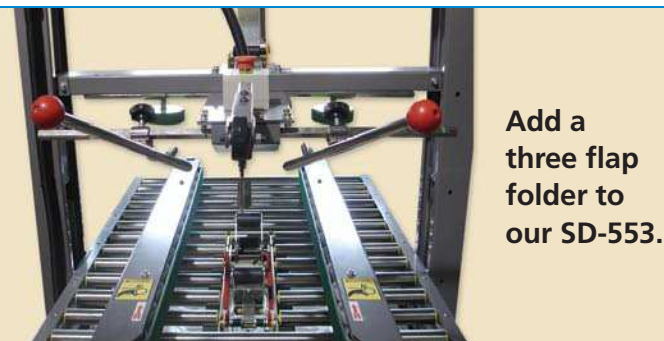
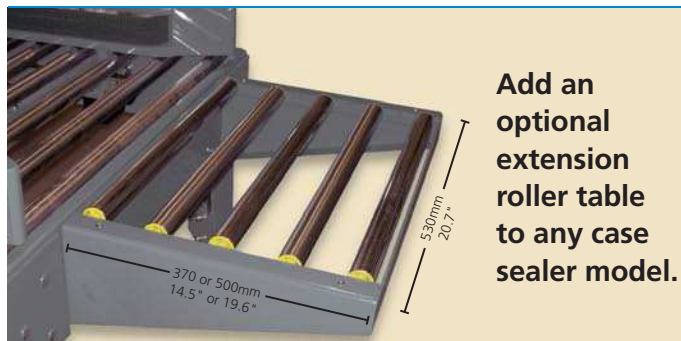

## PIRANHA OR BARRACUDA TAPE HEADS

- Robust and Simplistic Design
- Exact and Precise Sealing
- Professional looking packages
- Thicker Blade with deep sharp points which will cut consistently
- Single swipe seals, no wasting tape
- Also available in Stainless Steel



OUR BLADES



OTHER BLADES

Piranha

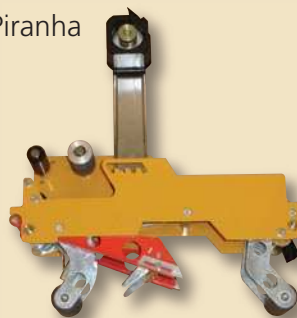

Barracuda

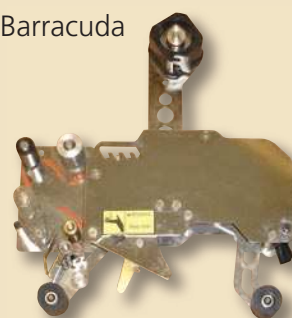

**The Piranha and Barracuda tape heads are the best on the market because of their simplicity, durability and affordability.**



**WAGNER  
PACKAGING  
MACHINERY**

WAGNER PACKAGING MACHINERY  
2904 DARTMOUTH DR. - PLANO TX 75075

T: 972.385.9456 / F: 972.499.1898

WWW.WAGNERPKG.ORG / WAGNERPKG@VERIZON.NET