

carrera

500 PC



www.ilapak.com



TECHNICAL SPECIFICATIONS

Machine speed	Up to 100 cpm, single jaw. Up to 200 cpm, twin jaws 150 mm - 5.9" centre Production output dependent upon product, film and machine specifications.
Product dimensions	
LENGTH	50/500 mm - 2/19.7" with any jaw centres and length
WIDTH	20/230 mm - 0.8/9" with jaw length 250 mm - 9.8" 20/300 mm - 0.8/11.8" with jaw length 325 mm - 12.8"
HEIGHT	Up to 90 mm - 3.5" with jaw centre 150 mm - 5.9" Up to 120 mm - 4.7" with jaw centre 180 mm - 7"
Film cut-off	Up to 630 mm - 24.8" Cut-off defined as: product length + height + 40 mm (1.6"), depending on product characteristics.
Wrapping materials	Suitable heat-sealable films, such as plain, or co-extruded polypropylene (PP), laminate films (e.g. OPP+PE), as well as cold-sealable films of suitable quality
Film reel dimensions	
CORE Ø	76 mm - 3"
OUTER Ø	350 mm - 13.8"
WIDTH	650 mm - 25.6"
Film reel max weight	40 kg - 88 lbs
Electronic Platform	Industrial PC
Power requirement	From 220 to 480 V, 50/60 Hz, 3-phase, 5 kVA
Compressed air	6 bar, 1 l/min with air gusseting
Machine weight	850 kg - 1874 lbs

MAIN STANDARD FEATURES

PC-controlled HFFS machine with rotary sealing jaws.

Multi-axis drive technology with 3 independent drive circuits consisting of an AC motor controlled by a frequency inverter for product infeed, sealing rollers and rotary sealing jaws.

A simple-to-use operator interface allows quick product change-over.

64 program memory; two-level password protection security.

Automatic adjustment of film-pull, infeed and sealing parameters during product or program change.

Precision temperature control circuits ensure seal strength and quality.

No product/No bag.

Single piece transparent guarding with safety interlock.

Robust mechanical construction with welded metal sheet main body, epoxy powder coating or (opt.) stainless-steel finishing.

Hygienic design with cantilevered body and infeed, for easy clean down.

Single film reel mounting with self-centering cones, right hand machine version, 2,5 m long infeed, standard.

Please discuss your needs with our local representative to configure this machine to your product's specific requirements.

ILAPAK is ISO 9001:2000 certified.

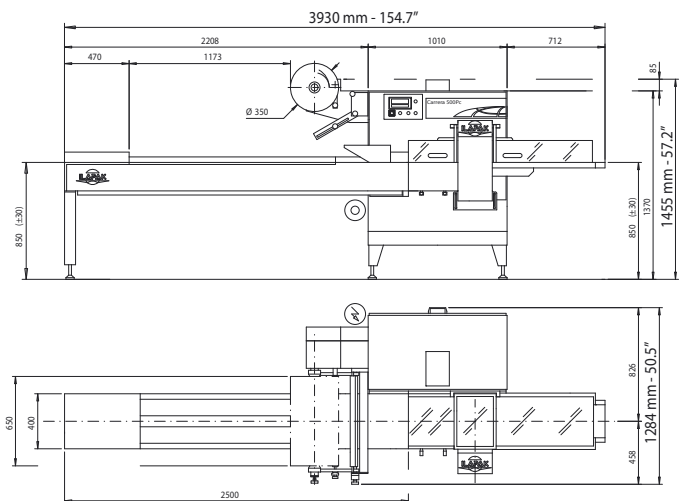

All measurements not specified in inches are given in millimeters.

These specifications are not binding. We reserve the right to change them without prior notice.



2904 Dartmouth - Plano, TX 75075
T: 972.385.9456 F: 972.596.3619

Lance@wagnerpkg.org
WWW.WAGNERPKG.ORG

www.ilapak.com



PACKAGING MACHINERY