

## SINGLE PISTON FILLING SYSTEM

## EXCELLENT FOR A VARIETY OF APPLICATIONS

*FOOD • COSMETIC • PAINT • CHEMICAL  
VETERINARY • PHARMACEUTICAL • AUTOMOTIVE  
PERSONAL CARE • THICK OR THIN PRODUCTS*



## DESIGN FEATURES

- HIGH ACCURACIES guaranteed to +/- 1/2 of 1% of the fill weight
- STAINLESS STEEL frame & wetted metal product contact parts
- VERSATILE filling system is capable of handling a wide range of products & volumes
- NO TOOL DISASSEMBLY for quick & easy clean up & change over
- LOWER INITIAL INVESTMENT cost compared to many competitors
- SPEEDS of 50+ cycles/minute

# SPECIFICATIONS

## STANDARD MACHINE FEATURES

Wetted metal contact parts of stainless steel

12 gallon stainless steel hopper

Fills from fractional ounces to 157 oz. with cylinder changes

Frame constructed of stainless steel

Built-in scale for setting the stroke length

Product contact system is held together with tri-clamp fittings

Pneumatically Powered  
Air Required 4 to 8 CFM @ 80 PSI

Spare Parts Kit & Operations Manual

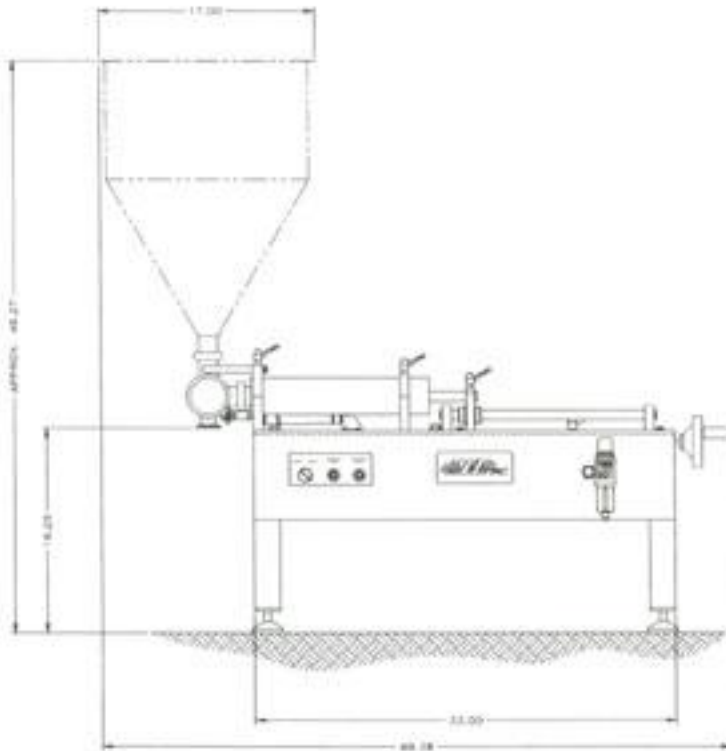

## OPTIONAL FEATURES

VARIETY OF SPOUTS & CUT-OFF NOZZLES

DUAL STAGE SPEED CONTROLS

HEATED VALVES & JACKETED HOPPERS

ADDITIONAL CYLINDER & PISTON SETS

POWERED CONVEYING SYSTEMS

AUTOMATIC CONTAINER INDEXING SYSTEMS

MULTI-STROKE CYCLE COUNTER

DIVING NOZZLE ASSEMBLIES

MANY HOPPER SIZES WITH A VARIETY OF AGITATOR STYLES



5408 3M DRIVE N.E.  
MENOMONIE, WI 54751

PHONE: 1-800-732-4624  
FAX: (715) 235-1880



**WAGNER  
PACKAGING  
MACHINERY**

T: 972-385-9456 F: 972-596-3619  
wagnerpkg@verizon.net / www.wagnerpkg.org



PEDESTAL MOUNTED MACHINE WITH OPTIONAL POSITIVE CUT-OFF NOZZLE