

# VOLUMETRIC PISTON FILLER

MODEL 305



Figure 1

## For Liquids, Creams, Pastes and Other Viscous Products

All-Fill's Model 305 Piston Filler is a versatile single head piston filler for liquids, creams, pastes, and other viscous products. Fill volumes can range from 50ml. to 2.5 liters per cycle with up to 60 fills per minute in either manual or automatic operation. During a filling cycle, a piston travels back to draw product from the hopper into a precision machined cylinder, then extends forward to fill. Product is dispensed into the container through a filling nozzle and/or cutoff device. Nozzles are available for single/multiple fill positions, or for specific products. Cutoffs prevent product from dripping after the fill.

### CHARACTERISTICS

- All Stainless Steel Construction and Pneumatic Operation ideal for wash-down environments and hazardous locations
- Secondary Fill Speed for tapered neck containers
- Wide range of Cylinder Sets, Nozzles, Cutoffs, and Accessories
- Conveyors and Indexing packages available for fully automatic operation
- Simple volume adjustment by hand crank

### WORLD CLASS SERVICE AND SUPPORT.

All-Fill uses quality off-the-shelf components so spares are readily available and costs are reduced. All programming is written and supported by in-house engineers.

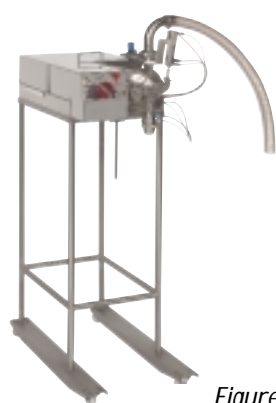
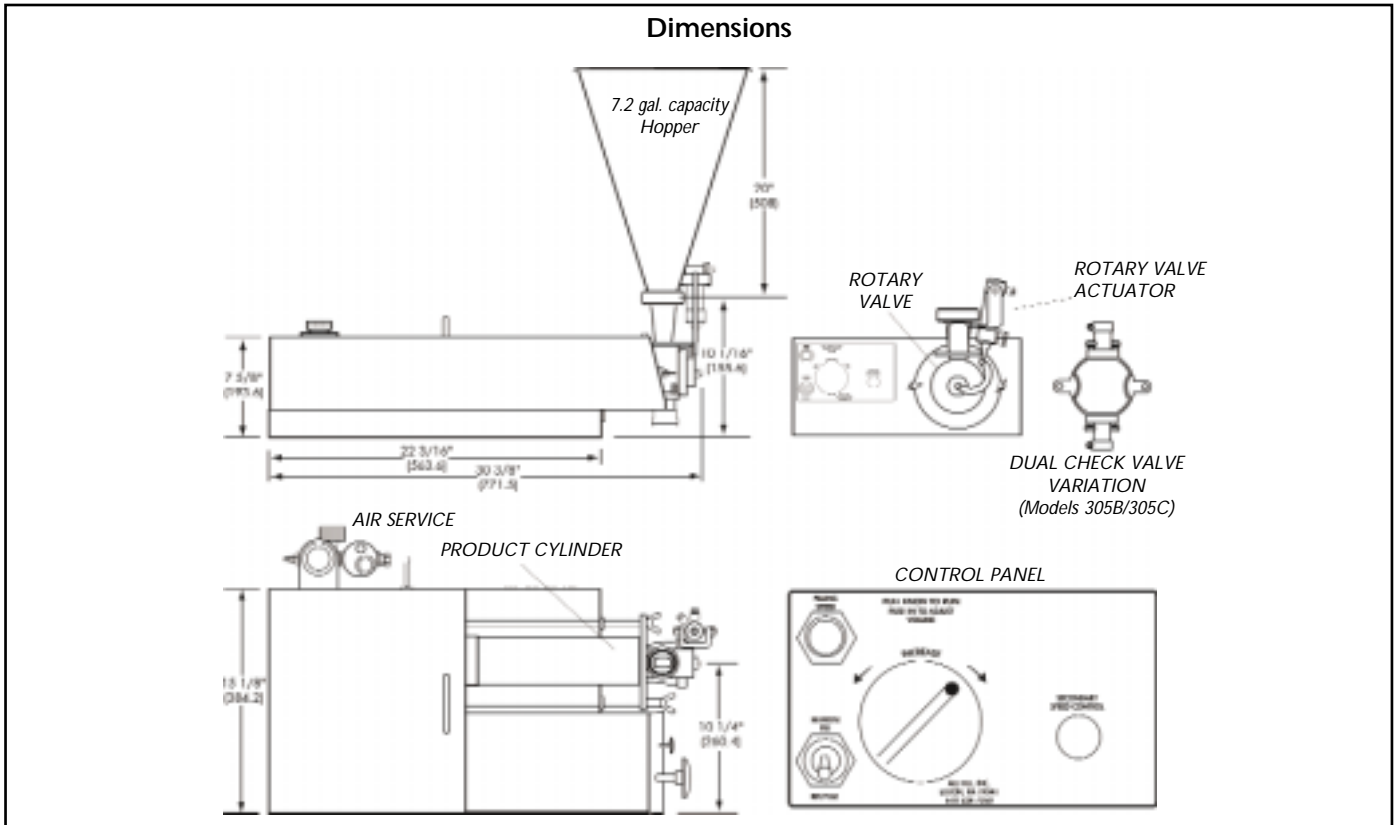

Figure 2

Portable Work  
Stand Accessory  
(Optional)



Figure 3



## CONTROLS

<b>Start Volume</b>	Controls operation of the piston filler Controls amount of product filled during operation	<b>Secondary Speed</b>	Provides speed control for final 10% of stroke
<b>Filling Speed</b>	Controls the speed at which product is dispensed	<b>Recharge Speed</b>	Controls the speed of the recharge (located under the hinged top cover)

Dimensions listed as reference only. Not to be used for layout or construction.

## SPECIFICATIONS

**Fill Volumes:** 1/3 to 87 fl. oz. (10-2600 ml) per single cycle. Additional volume available through multi-stroke operation (see "Accessories")

**Accuracy:** +/- 0.5%, typical

**Cylinder Size:** 1, 1-1/2, 2, 3, & 4-3/4" dia. available

**Hopper Capacity:**

Standard: 7.2 gal. (27.25 L)

Optional: 13 gal. (50 L)

**Air Requirements:**

80 psi @ 5 scfm

**Construction:**

Product Contact Parts: Stainless steel (hopper, enclosure, valve body, accessories)

Rotary Valve Rotors: Dairy Metal

### Accessories

Flow Actuated Valve, Multi-Stroke Control, Container Indexing, Conveyor, Level Control, Portable Stand, and Footswitch options are all available for the Model 305 Volumetric Piston Filler. Call ALL-FILL for details.



## All-Fill: For All Your Filling Needs.

All-Fill, Inc. designs, manufactures, services, and supports a complete line of machinery for powder and liquid filling. Complementary equipment includes feeding and conveying of dry products for the food, pharmaceutical, and chemical industries, as well as high-speed checkweighing equipment sold under the Alpha Checkweighers brand.

418 Creamery Way  
Exton, PA 19341 USA  
1-866-ALL-FILL  
Fax: (610) 524-7346



**WAGNER  
PACKAGING  
MACHINERY**

T: 972-385-9456 F: 972-596-3619  
wagnerpkg@verizon.net / www.wagnerpkg.org