



LOW COST SEMI-AUTOMATIC AUGER FILLING MACHINE

MODEL B-350e



For Dispensing Powders, Granules, and Liquids

The Model B-350e Auger Filling Machine is the latest development from ALL-FILL. The innovative design and improved PLC-based controls make it an affordable, reliable, auger filler with the same rugged construction and dependable service which ALL-FILL is renowned for.

The Model B-350e is ALL-FILL's answer to your "back to simplicity" filling need. Low cost, quick delivery, and extremely easy to operate - the Model B-350e can provide you with automated filling at a "bare-bones" expenditure.

CHARACTERISTICS

- "Off-the-Shelf" PLC Control and Operator Interface
- High Performance Clutch/Brake Control with Encoder and Coast Compensation
- Universal Filling Accessories
- 3-Speed Fill Motor Drive System
- Rugged Head Casting and Sturdy Base
- Quick and Easy Hopper and Filling Accessory Removal
- Fully Enclosed Agitation Drive
- One-Piece Stainless Steel Head Cover and Stainless Steel Contact Parts
- Optional Portable Frame With Jack Assembly
- Funnel Removal Detection

WORLD CLASS SERVICE AND SUPPORT.

All-Fill uses quality off-the-shelf components so spares are readily available and costs are reduced. All programming is written and supported by in-house engineers.

Dimensions & Specifications

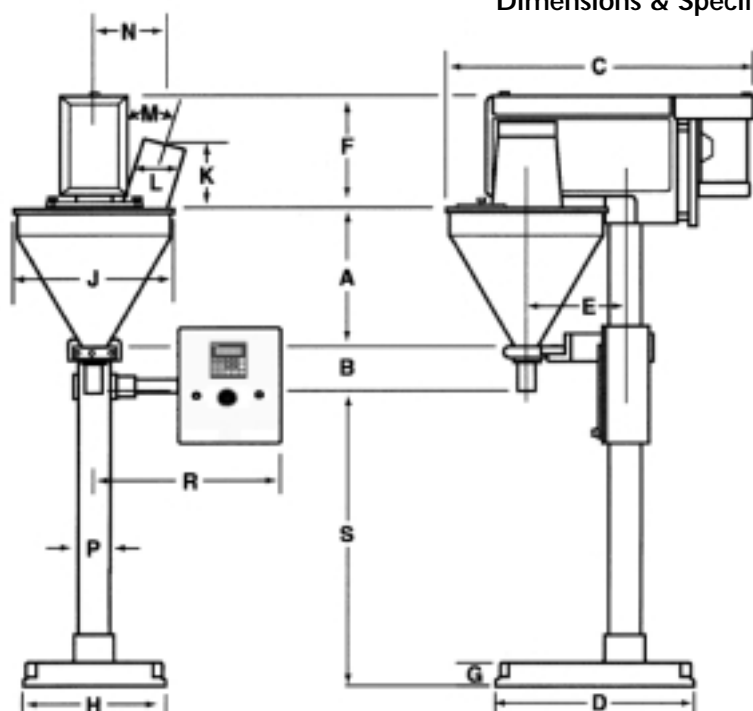

A	Hoppers	D	28" (711 mm)
	10 gal. (37.8L):	E	14" (356 mm)
	15 ³ / ₁₆ " (401.63 mm)	F	15 ³ / ₈ " (397 mm)
	16 ⁷ / ₁₆ " (417.51 mm)	G	3" (76 mm)
	16 gal. (60.5L):	H	20" (508 mm)
	19 ³ / ₁₆ " (503.23 mm)	J	22" dia. (559 mm)
	20 ¹ / ₂ " (520.70 mm)	K	8 ⁷ / ₈ " (252.42 mm)
B	Funnels	L	6" (152.40 mm)
	Short, No. 4-52: 5 ⁹ / ₁₆ " (141.28 mm)	M	15°
	Long, No. 4-52: 12 ² / ₁₆ " (319.08 mm)	N	9 ²³ / ₃₂ " (246.85 mm)
C	45" (1143 mm)	P	4 ¹ / ₂ " (114 mm)
		R	26 ¹ / ₄ " (666.75 mm)
		S	By Application

Electrical Motors : 208/230/460V, 60 Hz., 3-Phase
Controls: 120V, 60 Hz., Single Phase
Other ratings upon request

Weight 375 lb.
Crated Weight: 500 lb.
Crate Size: 48" H x 48" L x 96" W

Dimensions listed as reference only. Not to be used for layout or construction.

CONTROLS

- "Off-The-Shelf" PLC Control and Operator Interface
- Direct Entry of Auger Revolutions
- Agitation Mode (Continuous, With Fill, Off)
- Recycle Mode With Adjustable Dwell Time
- Hopper Empty Mode
- 5 Product Setup Capacity
- Coast Compensation
- Auger Jam Protection
- End of Fill/Hanshake Signal

Filling Accessories

Filling accessories are available in a wide variety of types and sizes to handle nearly any powder, paste, or liquid product. Fill weights from under 1 gram to 50 kg and beyond can be addressed.

Non-free-flow powders (talcum, spices, ground coffee, flour-based products, Ag-chems, toner) and free-flow products (salt, drink mixes, detergents, pool chemicals) can all be filled by All-Fill Auger Fillers. Heavy pastes and thin liquids can also be handled.

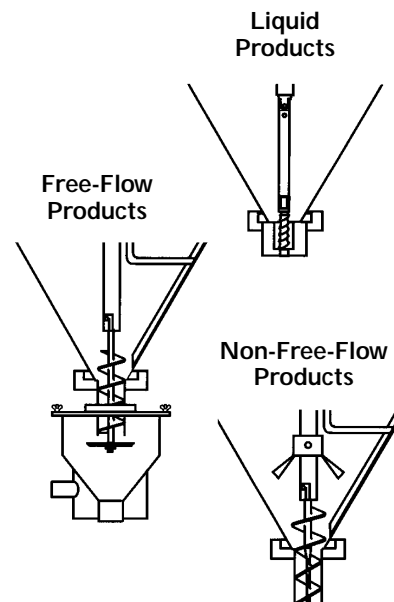

All-Fill: For All Your Filling Needs.

All-Fill, Inc. designs, manufactures, services, and supports a complete line of machinery for powder and liquid filling. Complementary equipment includes feeding and conveying of dry products for the food, pharmaceutical, and chemical industries, as well as high-speed checkweighing equipment sold under the Alpha Checkweighers brand.

418 Creamery Way
Exton, PA 19341 USA
1-866-ALL-FILL
Fax: (610) 524-7346



WAGNER
PACKAGING
MACHINERY
T: 972-385-9456 F: 972-596-3619
wagnerpkg@verizon.net / www.wagnerpkg.org