

## SERVODRIVE AUGER FILLER

MODEL B-SV-600



### For Powders, Granulars, and other Dry Products

All-Fill's Model B-SV-600 Auger Filler uses advanced technology — a brushless DC servo motor drive and field-proven PLC controls — to ensure fast, accurate, and reliable auger filling of dry products.

#### **SERVO RELIABILITY.**

All-Fill's coupling of a brushless DC servo motor directly to the auger drive shaft eliminates the need for a clutch/brake, belts, pulleys, and other parts subject to wear, thus reducing maintenance requirements and improving dependability.

#### **EFFICIENT PRODUCT HANDLING.**

Users can manage throughput via easy programming of the auger profile. Servo motor technology is ideal for fill-by weight applications that require multiple auger speeds, pauses, and feedback signals from scales or checkweighers.

#### **HIGH CYCLE RATES.**

All-Fill's servo motor drive features a rugged design for demanding duty and is available in a variety of torque ratings to match the application. It excels in filling jobs that exceed 100 cycles per minute.

#### **PLC ACCURACY.**

#### **TOUCHSCREEN EASE.**

Our PLC-based control system computes all relevant parameters (such as RPM acceleration/deceleration) internally, so the operator does not have to make calculations or complex entries. An intuitive touchscreen puts essential functions at the user's fingertips. Test and calibration screens simplify maintenance. Set-ups for products/fill weights are easily stored and recalled.

#### **WORLD CLASS SERVICE AND SUPPORT.**

All-Fill uses quality off-the-shelf components so spares are readily available and costs are reduced. All programming is written and supported by in-house engineers.

## SPECIFICATIONS

### Drive:

- a. Standard: brushless, low profile, high torque, direct drive servo motor available in 100-165-252 inch/lbs
- b. Optional: variable speed drive for slow speed agitation

**Motion control:** self-contained electronics package; servo uses 17 bit high resolution encoder (17 bits = 1/130000 accuracy)

**Head unit:** long-lasting head casting, machined for true alignment of motor, bearings, agitator, and other components; removable stainless steel cover for easy access

**Agitation gearmotor:** rugged, 1/2 HP, independent; slow speed product agitation; motor starter; chain drive; stainless steel agitator blade

### Hopper:

- a. 22"/559 mm dia stainless steel, 16 gal/60 liter capacity
- b. 22"/559 mm dia. stainless steel, dust-proof hopper cover with 6" infeed duct
- c. Self-aligning hopper coupling with quick disconnect for easy hopper removal (for cleaning or changeover)

### Other filler components:

- a. Mounting column with floor or 10"/254 mm round base
- b. Auger shaft
- c. Hopper alignment fixture

### Touchscreen control:

- a. 25 program selections
- b. Automatic alarm screens
- c. Automatic system status messages
- d. Auger, agitation, and cutoff setting options
- e. Intuitive maintenance screen — to display and check inputs and outputs

### Parameters:

- a. Adjustable auger speeds from 0-1500 RPM
- b. Adjustable acceleration/deceleration
- c. Accepts feedback from checkweighers

**Documentation:** complete package supplied as standard

Specifications subject to change without notice.

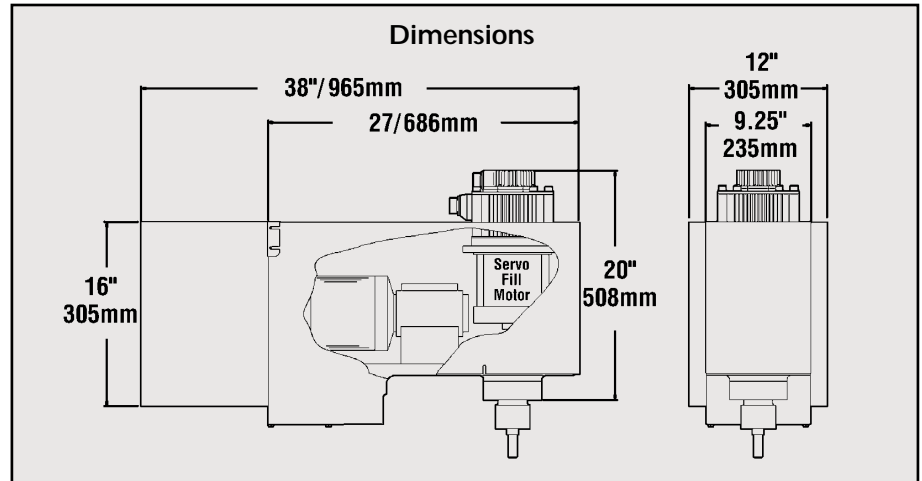

### Filling Accessories

Filling accessories are available in a wide variety of types and sizes to handle nearly any powder, paste, or liquid product. Fill weights from under 1 gram to 50 kg and beyond can be addressed.

Non-free-flow powders (talcum, spices, ground coffee, flour-based products, Ag-chemicals, toner) and free-flow products (salt, drink mixes, detergents, pool chemicals) can all be filled by All-Fill Auger Fillers. Heavy pastes and thin liquids can also be handled.

Interchangeable filling accessories can always be retrofitted to the machine as products and requirements change.

All-Fill maintains a complete test lab for conducting free evaluations.

### Servodrive Filling Heads Are Available on Every Type of All-Fill Automatic Filler

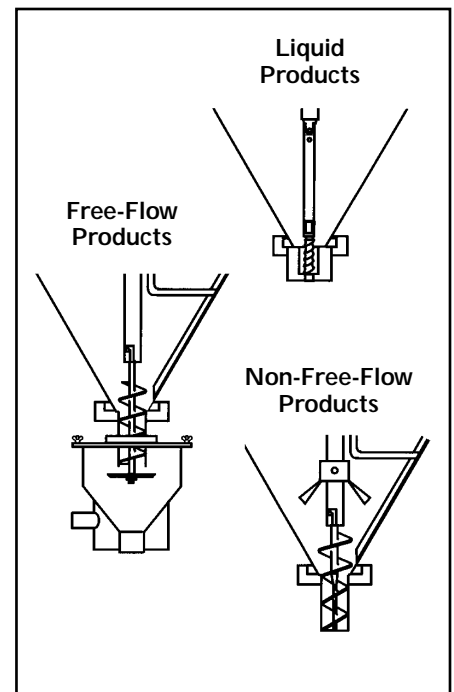

## All-Fill: For All Your Filling Needs.

All-Fill, Inc. designs, manufactures, services, and supports a complete line of machinery for powder and liquid filling. Complementary equipment includes feeding and conveying of dry products for the food, pharmaceutical, and chemical industries, as well as high-speed checkweighing equipment sold under the Alpha Checkweighers brand.

418 Creamery Way  
Exton, PA 19341 USA  
1-866-ALL-FILL  
Fax: (610) 524-7346

